

## CAPACITY COMPARISON:

### Concrete Cylinder or Cube Footing to DP-50 Diamond Pier<sup>®</sup>

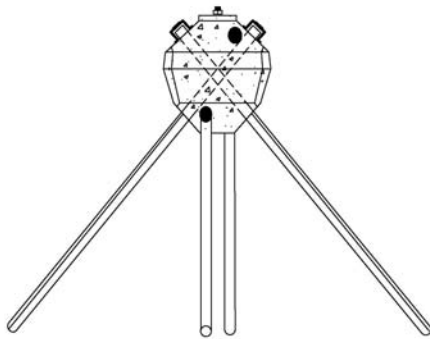

**DP-50**

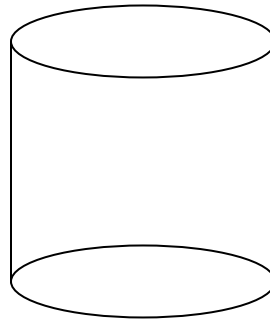

**Concrete Cylinder**  
18" dia. = 255 sq. in. = 1.77 SF

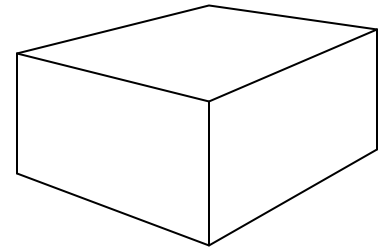

**Concrete Cube**  
16"sq. = 256 sq. in. = 1.78 SF

RESIDENTIAL SOIL TYPES IRC 2006/2009, Table R401.4.1	CAPACITIES		<b>Diamond Pier<sup>®</sup></b>
	CYLINDER	CUBE	
	18" dia.	16" sq.	<b>DP-50</b>
<b>2000 psf soil</b> Sands, silty sand, clayey sand, gravels clayey gravels, silty gravels	3540 #	3560 #	<b>3600 #</b>
<b>1500 psf soil</b> Clays, silts, clayey silts, silty clays sandy clays, sandy silts	2655 # (1.77 SF)	2670 # (1.78 SF)	<b>2700 #</b> <b>(1.8 SF Equiv. Bearing)</b>

- NOTES:**
1. Cylinder and Cube capacity are based on 12 inch depth into natural grade, or deeper cylinders, 2 to 4 feet down, formed in waxed or plastic forms to the full depth of the hole.
  2. Allowable loads utilize 4 Pins per Pier. Pin length includes that portion of the Pin embedded within the Pier.
  3. Tested settlement at design load is less than 1/2". See full report at [www.diamondpiers.com](http://www.diamondpiers.com).
  4. Where the building official determines that in-place soils with an allowable bearing pressure of less than 1500 psf are likely to be present at the site, the allowable bearing capacity shall be determined by a site specific investigation.

DP50CC-3/8/10